

Competition Framework



Youth Sport Trust

NETBALL Guidance Notes



Who is involved

England Netball has undertaken a complete review of competition opportunities across the player pathway. All participants want to compete, and the pilots that have been taking place within the national competition framework for young people show how many participants have been engaged in playing Netball. School Sport Partnerships are an important part of the integrated delivery of netball and England Netball sees the Framework as providing FUN and exciting competitive opportunities for any level of player.

National Contact

Matt Henaughan (School/Club Links Manager)

E-mail: MattH@englandnetball.co.uk Mob: 07738 697 231

Benefits

England Netball has reviewed all aspects of competition and the National Framework for Young People is part of that review for School Competition. The School-Club links programme is closely aligned to allow clear opportunities for young people to play netball in quality CAPS/Clubmark clubs at whatever level they wish to participate. Young leaders are encouraged to fulfil roles within the competition structure organisation.

Key Messages:

- Multi-skill activity at Key Stage 1 for a strong foundation for any sport
- High 5 Netball for Key Stage 2 learning the FUNdamentals of Netball and applying them in a FUN activity as well as participating in other sports.
- Different levels of competition for Key Stage 3 and above, providing FUN participation competition (Level 1) as well as identifying talented athletes to play at a higher level.
- Skill development according to the principles of Long Term Athlete Development.
- Disability Competition.

The Framework

Participation allows for all participants to play, not sit on the bench. Schools may take as many or as few players as they have. They may all play, as the teams can be determined on the day or made up with those that attend. As many as possible should play each week. Boys teams may also play in a boys' competition, at Key Stage 3.

Identified players may represent the SSP or the area SSPs. The competition is player-centred. It is to identify the best players, not the best school to win the league! This is a culture change that Schools will need to recognise. The PESSCL programme will help schools link to clubs that may be able to provide more opportunities for players to progress as well as support coaches and officials with the delivery.

Schools should target their students to achieve the highest percentage of students participating in competition, whether in festivals or leagues and make it easy for participants to 'dip' into competition, as well as making a commitment, when identified for Academies or England Netball Talent programmes.

Young volunteers from the schools are encouraged to attend courses and organise and be the officials for the competitions. England Netball has a Young Netball Organiser Award for teachers to deliver as well as a Youth Umpire award.

Delivery and Supporting resources

Netball's competition framework is structured in such a way as to facilitate flexible delivery, dependent on local need but based on a number of key principles. It sits closely with our other development programmes, particularly school-club links work, and should enhance and be supported by our new, club-based national competition structure at a local level.

Netball-specific Officers in the County Sports Partnerships are able to support the delivery in SSPs. Competition Managers in affiliated schools receive a Teacher Pack, a High 5 DVD and other resources, including a Young Netball Organiser course teacher pack, as well as magazines and posters. Your Regional unit will be able to support you in the delivery of the framework and our website www.englandnetball.co.uk is easy to access for other information.

Information for SCMs and CMs – Working with Netball

Key points of contact

The first point of contact for SCMs should be the England Netball Regional Manager (see table below). Dependent on the delivery structure in the local area, the RM will assist in providing contact details for county Netball Development Officers, Community Sports Coaches and/or county and club volunteers as appropriate.

How we would like to work with SCMs and CMs

Netball competition in schools is widespread throughout the country, however the delivery personnel for development work is variable. Where a county Netball Development Officer is in post, the RM will assist in forming a working partnership between the CM, RM, NDO, and CSP core team. In addition, where a county development group is in place it has proved particularly useful for the CM to link into this, providing benefits for both schools and clubs. In counties where no netball specific staff are employed, the RM will assist in providing links to club and county volunteer structures, in particular facilitating delivery of the framework through our holistic "5 stage model" for school-club links.

Existing data sources

We can provide from our national database a list of both accredited and non-accredited clubs in the county area. Data is also available on coaches, officials and tutors and this can be broken down by county. If you require any particular information please contact the Regional Unit and the Regional Administrator will be able to help. For localised information on club competition structures and suitability of exit routes or personnel, the NDO or county volunteers will be best placed to give you an accurate picture.

Key work for SCMs/CMs over the next 12 months

It is important that the delivery priorities are set based on local need, for example in some areas there may be inadequate provision of High 5 competition, in others KS 3 competition may only cater for small numbers and in others there may be an obvious opportunity for disability competition. It is likely therefore that these priorities will need to be determined locally in conjunction with the NDO, clubs and PDMs/SSCos. The working partnership outlined above should facilitate planning going forward.

In general we have found that a good place to start is with Key Stage 2 (9-11) years (High 5 Netball) and Key Stage 3 – Level 1 (participation emphasis). It is likely that Key Stage 3 – Level 2 (Talent ID) will be delivered from Year 2 onwards, however this is not to limit CMs should it be a focus in their particular locality.

Region	Regional Manager	Email	Phone
North West <i>Cumbria, Lancashire, Gtr Manchester, Merseyside, Cheshire, Isle of Man</i>	Dawn Tolcher	dawnt@englandnetball.co.uk	07818 036 791
North East <i>Northumberland, North Durham, South Durham, Cleveland, Tyne & Wear</i>	Jeannette Collins	jeannettec@englandnetball.co.uk	07818 036 792
Yorkshire & Humberside <i>North Yorkshire, South Yorkshire, West Yorkshire, Humberside</i>	Emma Brown	emmab@englandnetball.co.uk	07818 036 797
West Midlands <i>Worcestershire, Warwickshire, Shropshire, Herefordshire, Birmingham, Staffordshire</i>	Amy Willis	amyw@englandnetball.co.uk	07894 620 596
East Midlands <i>Leicestershire, Northamptonshire, Nottinghamshire, Lincolnshire, Derbyshire</i>	Gareth Hart	garethh@englandnetball.co.uk	07970 059 904
East <i>Bedfordshire, Hertfordshire, Essex (East & Thurrock), Norfolk, Suffolk, Cambridgeshire</i>	Emily St.John	emilys@englandnetball.co.uk	07818 036 799
South West <i>Wiltshire, Gloucestershire, Dorset, Somerset, Avon, Devon, Cornwall, Jersey</i>	Kathryn Crago	kathrync@englandnetball.co.uk	07793 245 534
South <i>Berkshire, Buckinghamshire, Hampshire, Oxfordshire, Guernsey, East Sussex, West Sussex, Isle of Wight</i>	Jenny Hotchkiss	jennyh@englandnetball.co.uk	07818 036 796
London & South East <i>Essex Met, Kent, Surrey, Middlesex, London Boroughs</i>	Lauren Templeton	laurent@englandnetball.co.uk	07818 036 795

Primary Framework



Competition framework descriptor	Recommended competition	Level and location	Scheduling	Next steps in competition
<p>Key Stage 2: 7-9 years</p> <ul style="list-style-type: none"> Multi-skill festivals (termly) Theme based 	<ol style="list-style-type: none"> Multi-skill festivals with generic skills included in performance standards TOPS 2 active games 	<ul style="list-style-type: none"> flexible and moveable venues relevant to host schools and according to local need 	<ul style="list-style-type: none"> have a generic festival with different theme, e.g. throwing, running, jumping striking, etc 	<ul style="list-style-type: none"> FUNDamentals of netball and employment of these skills in a game context
<p>Key Stage 2: 9-11 years</p> <ul style="list-style-type: none"> Multi-sport competition (six week block rotation) Central venue leagues Coaching and competition based on primary, secondary or club sites Menu of options available for flexibility of venue and competition 	<ul style="list-style-type: none"> High 5 (mini-game) Single sex or mixed Festival league competition at a moveable central venue Coaching and competition with emphasis on participation 	<ul style="list-style-type: none"> Primary school clusters at flexible venues May be held on secondary school site for any child or school (does not have to enter as part of school team) Does not have to enter each week Important that best boys who play in all teams are not sent to win for the school 	<ul style="list-style-type: none"> Three half-terms between September and April, with one held in an indoor venue 	<ul style="list-style-type: none"> Continue enjoying participating in fun leagues until reach secondary school

Primary Organisers Sheet



Competition age group	Format	Facilities	Organiser/helpers	Equipment	Resources available from NGB to support
Year 5/6	<ul style="list-style-type: none"> • four x six minutes with rotation of positions • week • competition • enter, even if not part of school team, to encourage high numbers of participants 	<ul style="list-style-type: none"> • courts dependent upon number of teams 	<ul style="list-style-type: none"> • of teachers • not on using the same players in every sport (e.g. the boys from the rugby/football teams) 	<ul style="list-style-type: none"> • Bibs (High 5) • 9 foot post • Balls – size 4 	<ul style="list-style-type: none"> • <i>How to Organise a High 5 Event Teachers' Pack</i> • Young Netball Organiser Course • Junior Umpiring Award • High 5 DVD • <i>School – Club Links Handbook</i>
All disability (learning disability and/or deaf) competition is High 5 or seven-a-side according to local need					

Secondary Framework



<p>Key Stage 3: 11-12 years</p> <ul style="list-style-type: none"> • Multi-sport competition (monthly, three sports) • E.g. central venue, leagues in a range of sports, coaching and competition at secondary, hub or club sites 	<p><u>Year 7</u></p> <ul style="list-style-type: none"> • Level 1, 2 (see below) • Level 1 is central venue, leagues, between September and March • Year 7 should be moving to a seven-a-side game from the five-a-side mini-game so that coaching will encompass this 	<ul style="list-style-type: none"> • Central venue although could be moved round the partner secondary schools 	<ul style="list-style-type: none"> • Weekly, September – April • (Calendar will be provided for levels and weeks!) 	<ul style="list-style-type: none"> • Level 2 individuals representing the SSP against other SSPs in the county/area selected by teachers/coaches (if support required)
--	---	---	--	---

<p>Key Stage 3 and 4: 12-16 years</p> <ul style="list-style-type: none"> • Intra- and inter-school leagues and cup competitions within SSPs (year group teams) • Intra- and inter-school leagues • Teachers allow for maximum participation <p>Level 2</p> <ul style="list-style-type: none"> • Teachers/coaches attended Performance Standard Workshop (PSW) and Talent Development Workshop (TDW) are able to nominate to EN talent programmes • Teachers/coaches will select from SSP <p>Level 3</p> <ul style="list-style-type: none"> • Managed programme for these players, with players' passport recording competition • TASS/regional head coaches all attended TDW 2 to identify for EN talent programmes 	<ul style="list-style-type: none"> • Age groups will be according to SSP numbers, but may be either in single year groups, Year 8, 9, 10, 11, or combined year groups, Years 8 and 9, Years 10 and 11 <p>Level 1</p> <ul style="list-style-type: none"> • All pupils, all schools • All age groups, 11-16 years • After-school, Monday – Friday • Inter-school within SSP <p>Level 2</p> <ul style="list-style-type: none"> • Identified talented players from Level 1 only • Years 7-9 and Years 9-11 • After-school, Monday – Friday, possibly weekends where it does not clash with club leagues • Best athletes within SSPs in area • Intra-regional <p>Level 3 (Not likely to happen until Year 2 or 3 of pilot)</p> <ul style="list-style-type: none"> • Identified talented players from Level 2 only • Years 9-11 • Inter-regional within two area groups (e.g. North and South) • Two squads x ten from each region • Regional finals at Easter (nine x one squad) to link with club 	<ul style="list-style-type: none"> • could be moved round the partner secondary schools <ul style="list-style-type: none"> • could be moved to different venues in the county • encouraged <ul style="list-style-type: none"> • according to travel needs • for some use 	<ul style="list-style-type: none"> • – April <ul style="list-style-type: none"> • March. Calendar to be provided so that Level 2 participants do not compete in Level 1 competitions <ul style="list-style-type: none"> • – March (not December) • Easter 	<ul style="list-style-type: none"> • representing the SSP against other SSPs in the area. Level 2 athletes may return to Level 1 competition when Level 2 not being played <ul style="list-style-type: none"> • talented players from the region in inter-regional competition within two area groups, e.g. North and South • clubs in regional leagues
--	---	---	---	--

	<ul style="list-style-type: none"> competition to include best athletes from both schools and clubs (Possibly play on Franchise Super League days) 		
--	---	--	--



Secondary Organisers Sheet

Competition age group	Format	Facilities	Organiser/helpers	Equipment	Resources available from NGB to support
Year 7 – 11 Level 1/2/3	<ul style="list-style-type: none"> four x ten minutes match per week. Round robin competition Level 2/3 	<ul style="list-style-type: none"> courts dependent upon number of teams 	<ul style="list-style-type: none"> of teachers or AOTTs/teacher players/coaches/officials young people, not the best school, so that only talented players move through to Level 3, representing county/area schools or regional schools 	<ul style="list-style-type: none"> Bibs 10 foot post Balls – size 5 	<ul style="list-style-type: none"> <i>How to Start a Junior League</i> Young Netball Organiser Course Junior Umpiring Award <i>School – Club Links Handbook</i>
All disability (learning disability and/or deaf) competition is High 5 or seven-a-side according to local need					

All SSPs should look to link with the PESSCL Strategy, especially for training courses. Timing of school leagues should be in consultation with local club competitions

Diagrammatic Aides



National Competition Structure for Young People

School Sport Partnerships

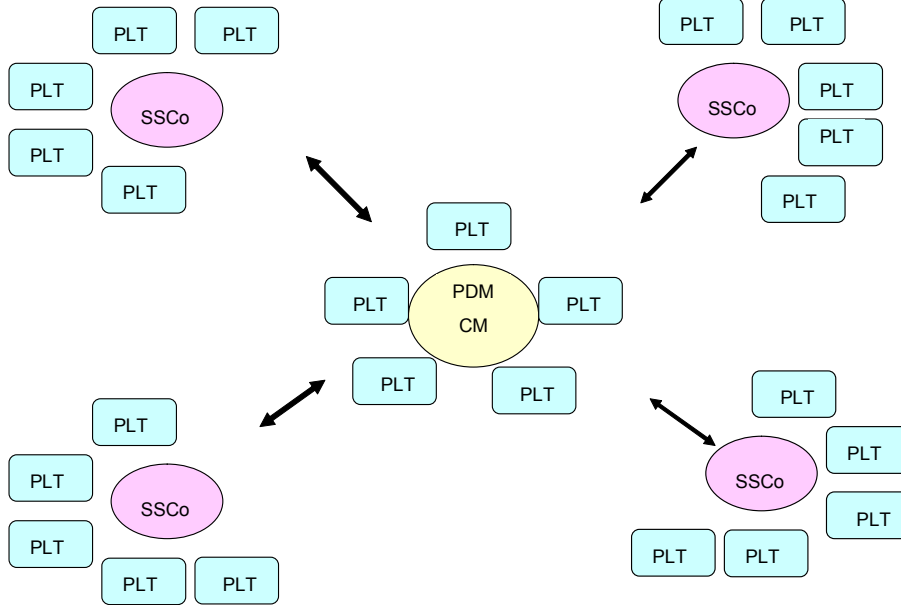

1

National Competition Structure for Young People

School Sport Partnerships

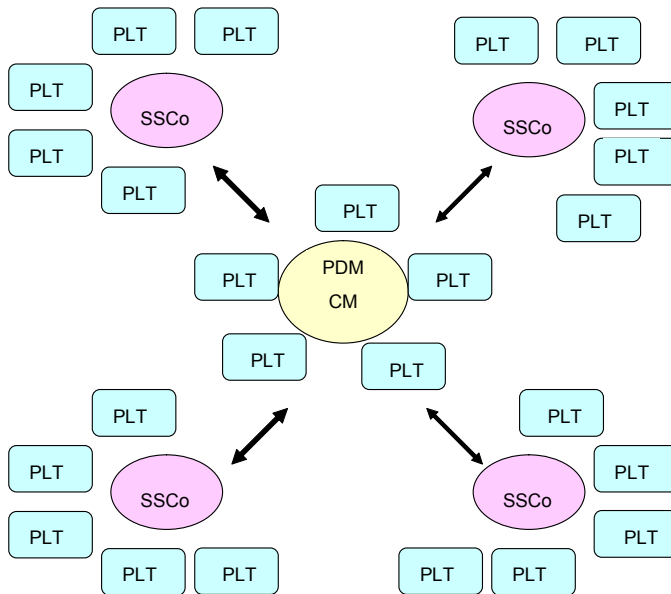

Netball has embedded the principles of Long Term Athlete Development in competitions for schools. The National Framework has two key objectives:

- greater opportunity to participate in quality competition
- competition for talented players/athletes.

School Sport Partnerships are key to enabling young players to achieve their potential within competition.

The young players with identified potential to develop, will access competition relevant to those individual needs.

2

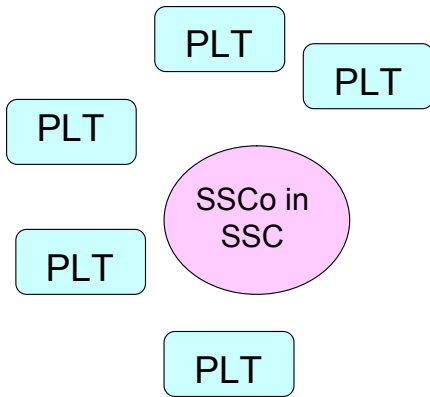

KEY STAGE 2: 7-9 YRS

- Multi-skills festivals (termly)
- Theme based with generic skills to achieve Performance standards
- Primary school clusters with flexible and moveable venues according to local need

SCHEDULE - TERMLY

KEY STAGE 2: 9-11 YRS

- Multisport
- H5 Netball, single sex or mixed
- Festival league competition at secondary school site (flexible)
- Coaching and competition with emphasis on participation
- Players do not have to enter as part of school team
- Important for all to participate not 'best boys' who play in all teams sent to win

SCHEDULE:- Half -termly between September and April with one held in an indoor venue. Festivals to be staffed by students in Secondary school having completed YNO, Jnr Umpire award or CSLA.

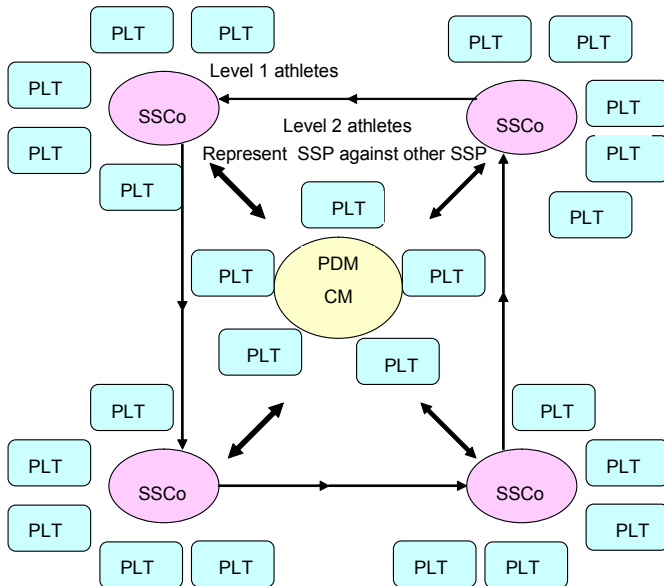

Key Stage 3/4

Level 1
Participation for all players to enter, not just school team
Yr7, 8 + 9, 10 +11
Competitions within SSP

Level 2
Identified athletes to represent SSP against other SSPs in Area

Level 3
Identified athletes to represent Area SSPs in Regional Competition

Level 3 athletes
Represent area SSPs in regional competition

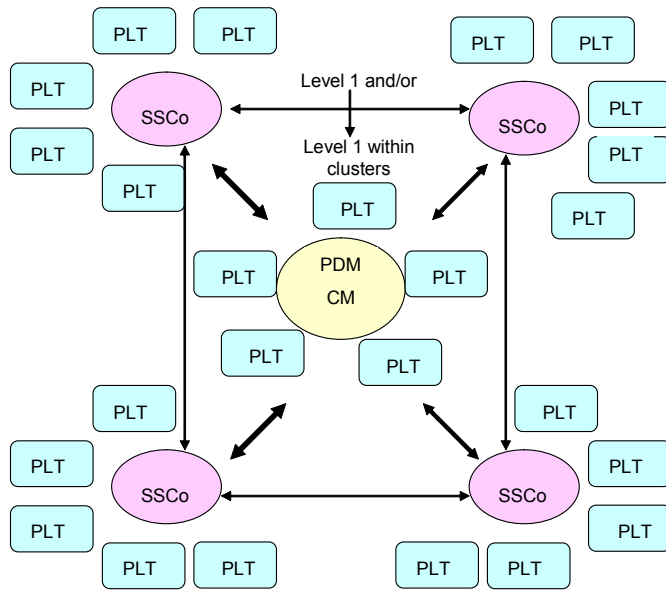

Level 2 representing SSP against other SSPs

Level 1: Participation

- Integration with Level 1 competition depending on disability or special school

or

- Separate learning disability festival competition

Level 2 for LD between schools in SSP

Level 3 is equivalent to previous Level 2, playing for SSP against other SSPs

England Netball Junior Competition

Club Competition

